

Horizontal Machining Center

# SH Series

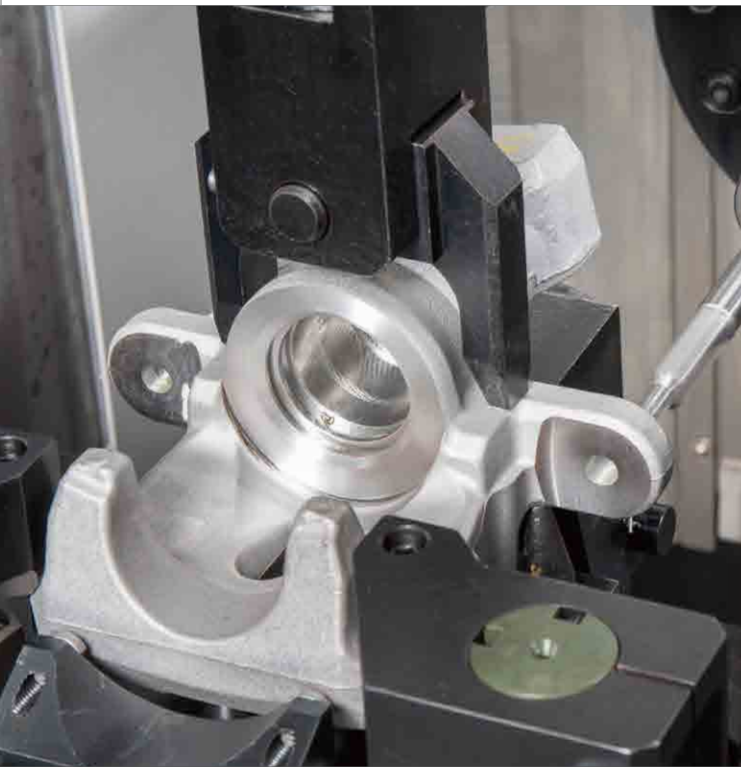

# SH Series

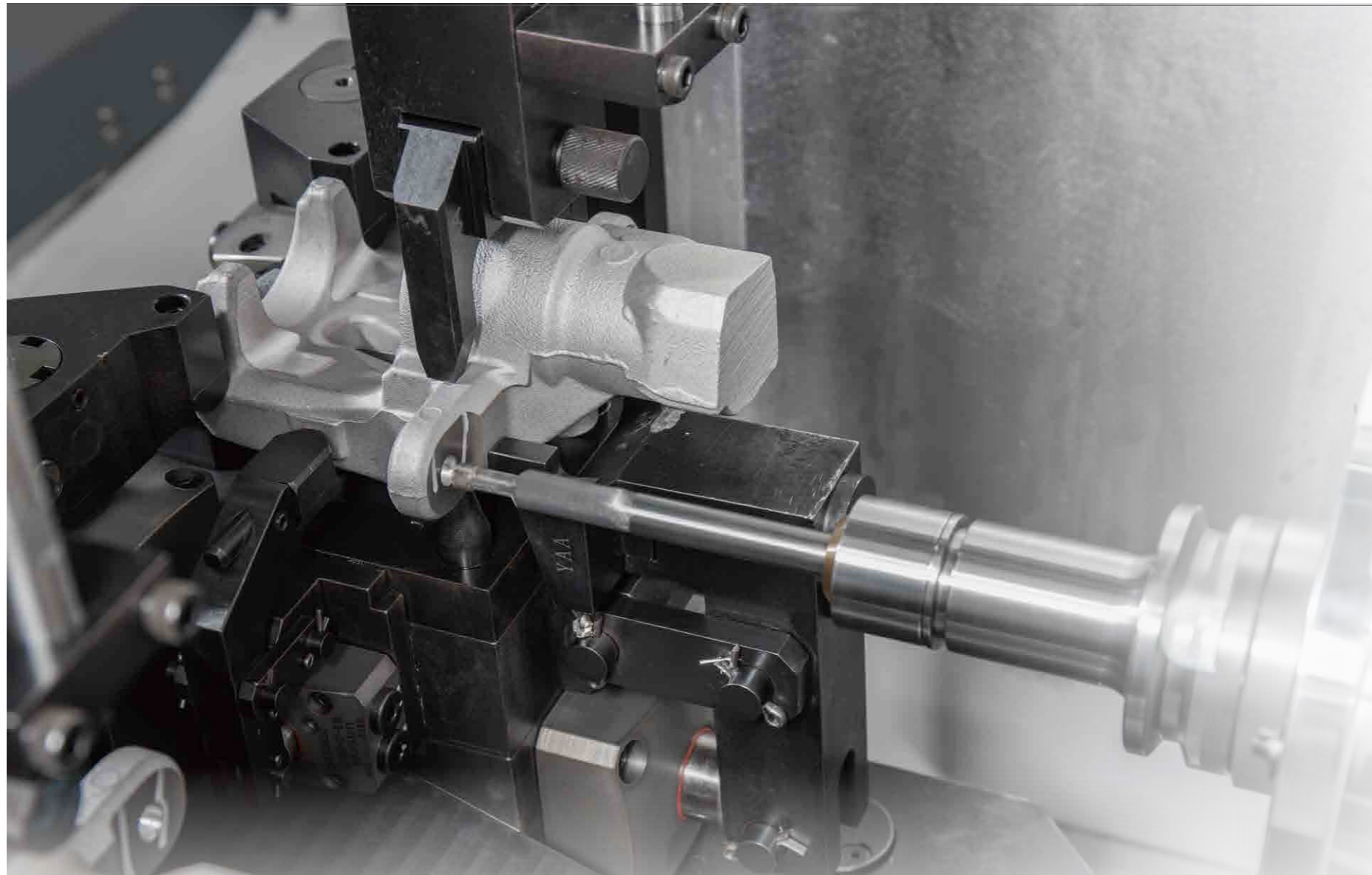

- SH series is developed for smaller stroke need and aluminum parts machining. It is equipped with 15,000 rpm built-in spindle which has 18.5/26/37 kW power and 95/171/250 Nm torque output. In addition, for customers considering the requirements of cycle time and loading/unloading time, the APC (automatic pallet changer) system is available as an option.
- Machine bed adopts 3-point support structure which facilitates leveling adjustment and ensures a stable machine installation.
- X axis roller guide ways are set on stepped bed. This further increases structure rigidity, lightens structure weight, and saves floor space.
- Minimized machine width design benefits the mass production line planning.



## Main specification

Spindle	15,000 rpm built-in spindle
3 axes	Rapid traverse 60 m/min
	X/Y/Z axis stroke 510/510/510mm [SH-4000(P)]
	X/Y/Z axis stroke 630/630/730mm [SH-4500(P)]
	X/Y/Z axis stroke 730/730/830mm [SH-5000(P)]
	X/Y/Z axis acceleration/deceleration 1.0 G [SH-4000(P)]
B axis rotary table	X/Y/Z axis acceleration/deceleration 0.8/1/1 G [SH-5000(P),SH-4500(P)]
	X/Y/Z axis □45 mm high rigidity roller guide way
	X/Y/Z axis Ø40 mm high precision ballscrew
	0.001° indexing table
	Table size : 400 x 400, 500 x 500 mm
	Max. workpiece size : Ø550 x H800 mm [SH-4000(P)]
	Max. workpiece size : Ø630 x H900 mm [SH-4500(P)]
Max. workpiece size : Ø800 x H1000 mm [SH-5000(P)]	

## CONTENTS

- 03 Industrial applications
- 05 Main structure
- 08 Operation
- 09 Peripheral accessories
- 12 Flexible Manufacturing System
- 13 TMS
- 15 Working area · Spindle output and chart 16
- Machine dimensions
- 17 Standard/optional accessories
- 18 Specification

# Industry applications

Suitable for mass production line planning & aluminum machining.

SH-4000P

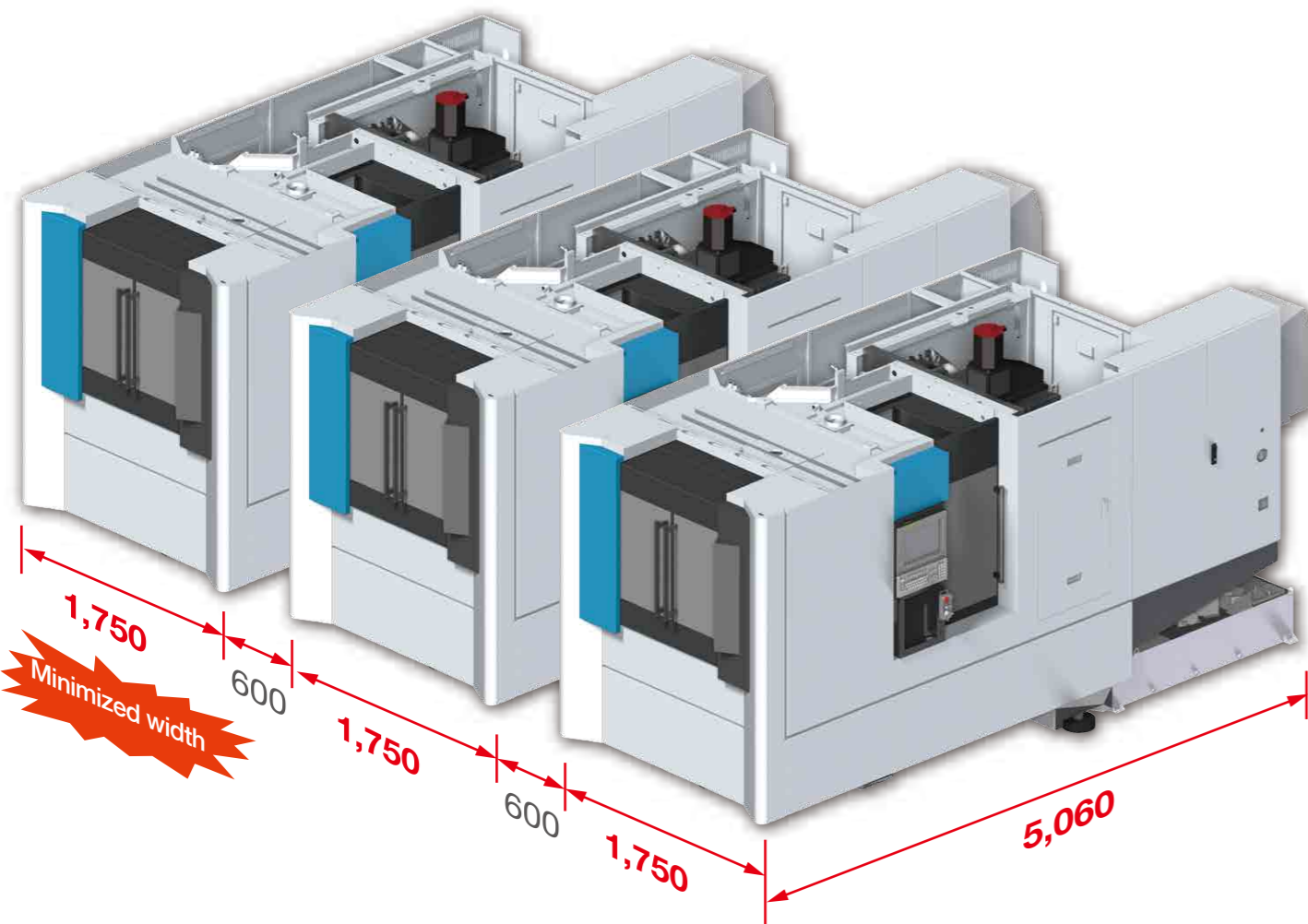

Item	Unit	SH-4000P	SH-4500P	SH-5000P
Width	mm	1,750	2,200	2,290
Depth	mm	5,060	5,700	5,840



Workpiece: Caliper  
Material: Aluminum alloy



Workpiece: ABS breaking valve  
Material: Aluminum alloy



Workpiece: Differential cover  
Material: Aluminum alloy

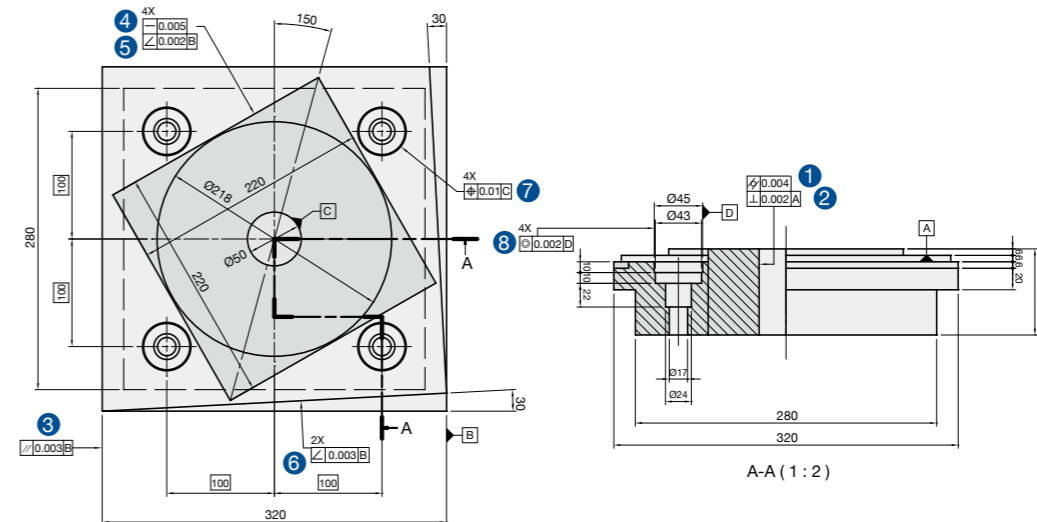

Test standard : ISO10791-7  
Material : A6061

Test items	Test accuracy
① Cylindricity	0.003
② Perpendicularity	0.002
③ Parallelism	0.005
④ Straightness	0.005
⑤ Angular accuracy	0.003
⑥ Angular accuracy	0.006
⑦ Position accuracy	0.007
⑧ Concentricity	0.006

### Three axes accuracy

Test standard : VDI3441

	Positioning accuracy	Repeatability accuracy
X axis	3.10	2.92
Y axis	3.9	2.84
Z axis	3.0	2.53
	Positioning accuracy with linear scale	Repeatability accuracy with linear scale
X axis	2.65	1.12
Y axis	2.16	0.95
Z axis	2.33	1.42

\*The above data is measured in-house. The test result may not be obtained due to differences cutting conditions and environment conditions.



Face mill Ø80mm		
Material	A5052	S45C
Depth/Width	2/65	5/65 mm
Spindle speed	12,000	900 rpm
Feed rate	16,000	945 mm/min
Chip removal rate	2080	307 cm <sup>3</sup> /min



Ø35mm 鑽頭	
Material	S45C
Spindle speed	200 rpm
Feed rate	70 mm/min
Chip removal rate	87 cm <sup>3</sup> /min



Face mill		
	Ø18	Ø16 mm
Material	A5052	S45C
Depth/Width	30/3.8	20/12 mm
Spindle speed	12,000	1,000 rpm
Feed rate	20,000	600 mm/min
Chip removal rate	2280	144 cm <sup>3</sup> /min



M30P2.5 攻牙	
Material	S45C
Spindle speed	105 rpm
Feed rate	371 mm/min

# Main structure

## High rigidity structure

### Stroke

X/Y/Z axis 510/510/510 mm [SH-4000(P)]

X/Y/Z axis 630/630/730 mm [SH-4500(P)]

X/Y/Z axis 730/730/830 mm [SH-5000(P)]

### Rapid traverse

X/Y/Z axis 60/60/60 m/min

### Acceleration/Deceleration

X/Y/Z axis 1.0 G [SH-4000(P)]

X/Y/Z axis 0.8/1/1 G [SH-5000(P),SH-4500(P)]

### Max. workpiece size

Max. workpiece size	diameter x height
SH-4000(P)	Ø550 × 800 mm
SH-4500(P)	Ø630 × 900 mm
SH-5000(P)	Ø800 × 1000 mm

- Double-wall and symmetrical structure design are used on the motion column to improve structural rigidity and reduce accuracy errors caused by thermal distortion.
- DHoneycomb structure of motion column helps to reduce weight by 25% and improve rigidity by 20%.

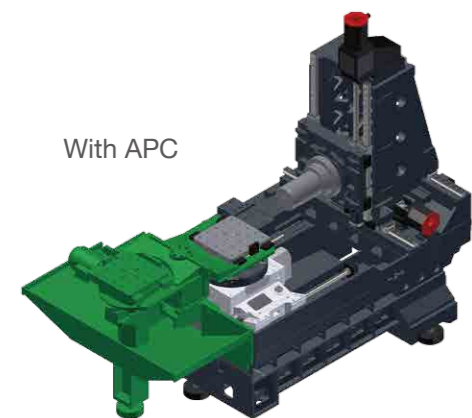
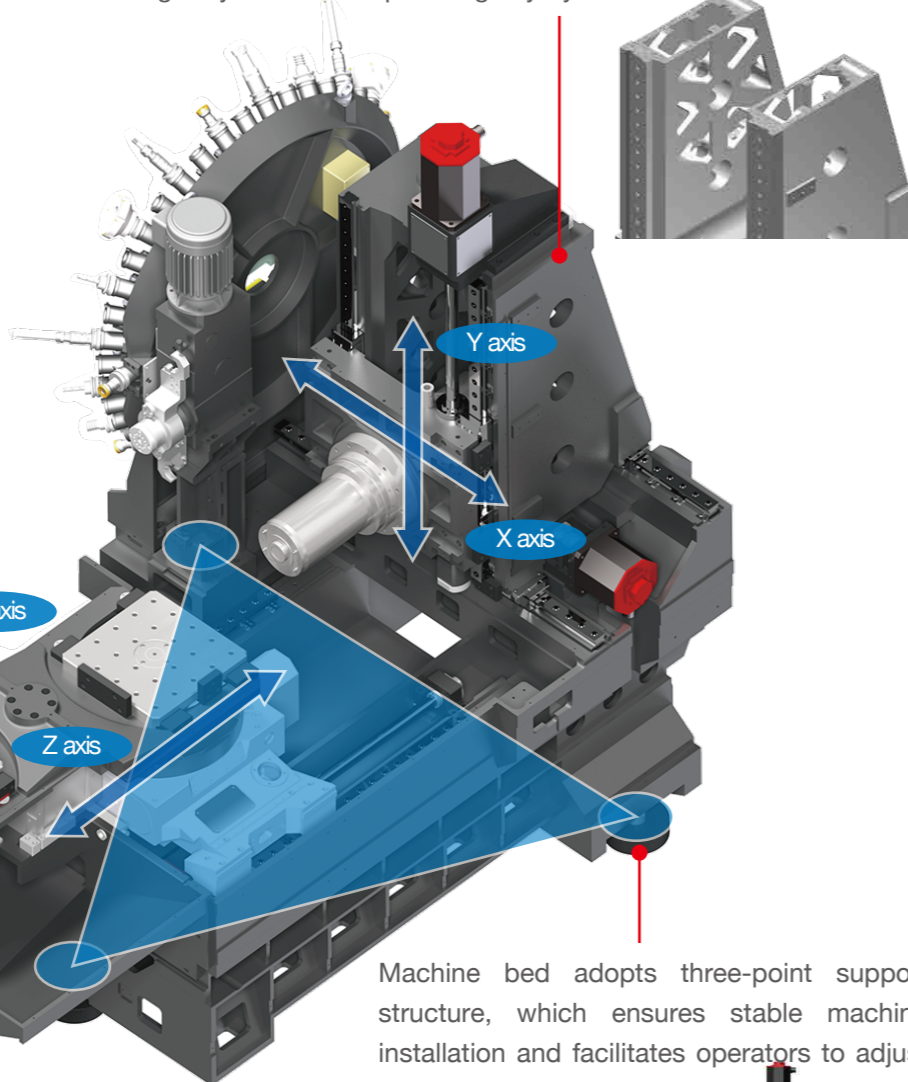

With APC



Without-APC

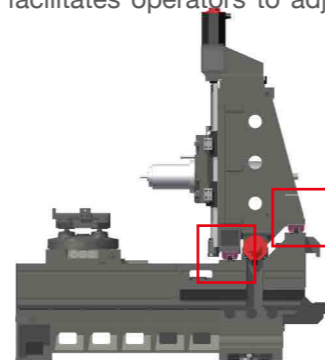

X axis roller guide ways are set on stepped bed, which not only increases structure rigidity but also achieves the goals of weight decreasing and floor space saving.

Considering the requirements of cycle time and loading/unloading time, an APC (automatic pallet changer) system is available as an option.

## Spindle

Max. spindle speed 15,000 rpm

Spindle motor 18.5/26/37 kW

Output torque 95/171/250 Nm

Acceleration time 0.48 sec (0→7,000 rpm)

0.95 sec (0→11,000 rpm)

1.9 sec (0→15,000 rpm)

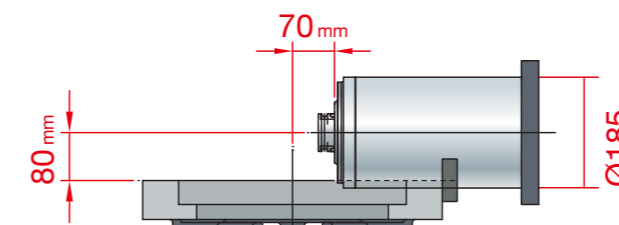

Minimum distance from spindle nose to table center 70 mm

Minimum distance from spindle center to table surface 80 mm



performance in aluminum alloy part, the machine is equipped with 15,000 rpm built-in spindle which has 18.5/26/37 kW power and 95/171/250 Nm torque output.

High precision positioning cones with hydraulic locking device, generating 4.2 tons of clamping force to ensure the table stability during machining.

## B axis rotary table

### High rigidity roller gear cam mechanism

Because B axis rotary table is driven by roller gear cam with rolling contact between roller and cam, it can start at a lower torque. It is suitable for high speed rotation and high accuracy is guaranteed under long-term heavy duty cutting.

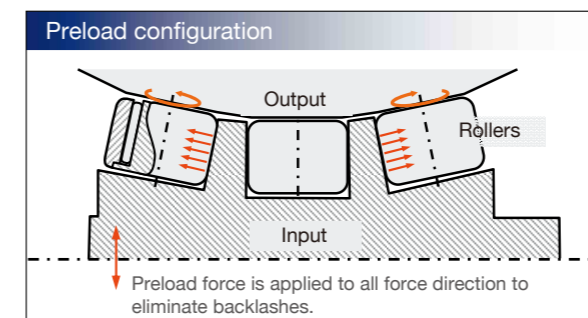
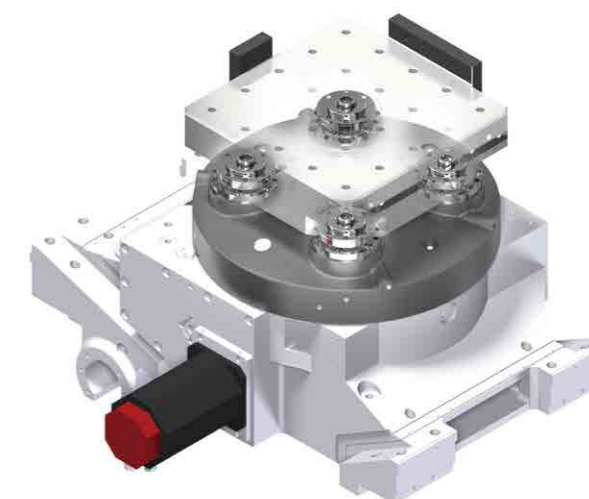

Zero backlash	Low abrasion
High positioning accuracy	Higher durability

	SH-4000(P)	SH-4500(P)	SH-5000(P)
Max. table load	400kg	450 kg	500 kg
Min. indexing degree of table	0.5 sec	0.63 sec	0.76 sec
90°indexing time of table	0.001°		
Clamping force of table	4,200 kg		
Braking force of table	500 kg.m		
Positioning accuracy of B axis	15"		
Repetition accuracy of B axis	4"		

\*VD13441

# Main structure

## APC (Automatic Pallet Changer)(SH-4000P)

Cam type device driven by electric motor is used on APC system. It has the advantages of quick pallet changing, less noise, and stable working since isn't influenced by oil temperature.

Pallet changing time	
SH-4000P	6.0 sec (Full loading)
SH-4500P	6.5 sec (Full loading)
SH-5000P	7.0 sec (Full loading)

## ATC (Automatic Tool Changer)

Japanese made cam mechanism is used on ATC gear box, which has the features of high stability, high durability, and rapid tool changing. A ring -type magazine (40 tools) is equipped to offer high speed indexing. Tool moving time of next adjacent tool is 2.82 sec.

Allowable tool sizes in ATC

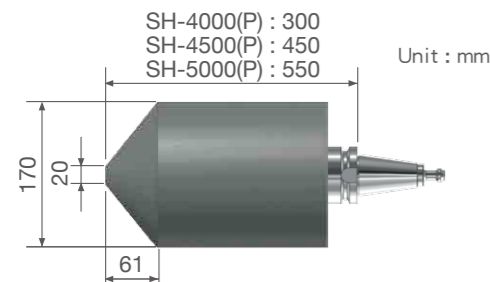

	SH-4000(P)	SH-4500(P)	SH-5000(P)
T to T time	1.4 Sec	1.4 Sec	1.4 Sec
C to C time	2.6 Sec	2.8 Sec	3.0 Sec
Tool capacity	40 \ 60(Opt.)		

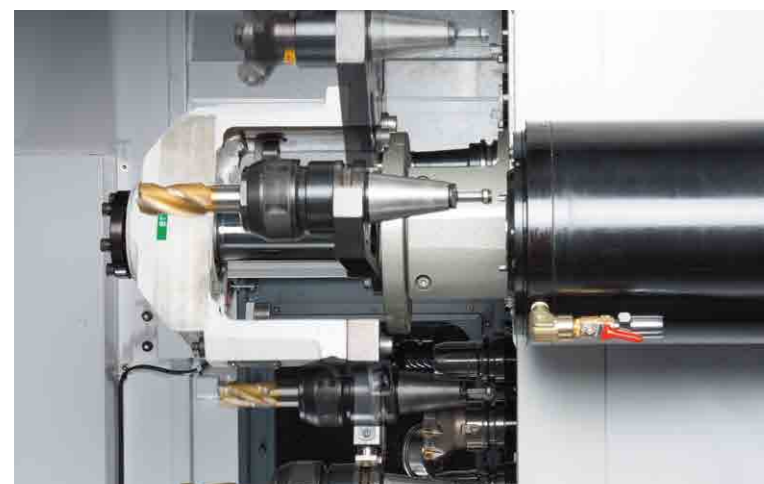

# Operation

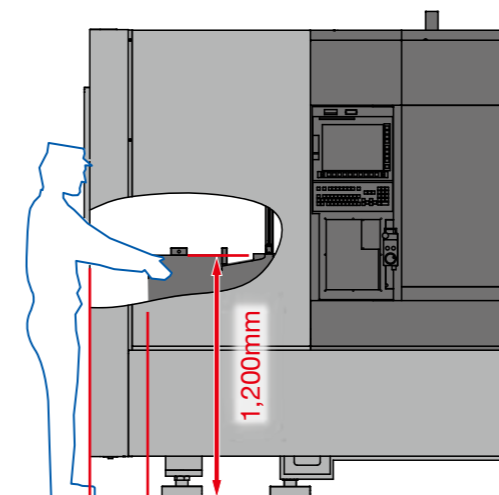

SH-4000 : 140 mm  
SH-4500 : 190 mm  
SH-5000 : 215 mm

With excellent access to the table and a wide door opening facilitates loading/unloading and jig & fixture operations.

SH-4000P : 680 mm  
SH-4500P : 760 mm  
SH-5000P : 930 mm



SH-4000(P) : 450 mm  
SH-4500(P) : 400 mm  
SH-5000(P) : 350 mm



Through centralized management of air FRL unit and lubrication pump, daily maintenance becomes easier.



A big size tool magazine door design facilitates tool checking and replacement.

# Peripheral accessories

## Rearward type chip conveyor

Standard equipped integrated type (chain type plus drum type) chip conveyor, it has outstanding chip disposal efficiency for different materials and chip size.

○ : suitable × : non-suitable

Integrated type (chain type plus drum type)	Steel		Cast iron		Aluminum/ non-ferrous metal		
	Long/Curl chips	Short chips	Powder chips	Short chips	Long/Curl chips	Short chips	Powder chips
	○	○	○	○	○	○	○

Short chips: Chips shorter than 60 mm or ball type chips smaller than Ø40 mm.  
Curl long chips: Chips' length is longer than short ones.



Coolant tank capacity: 700 L(80% full)

## C.T.S. (Coolant through spindle) (optional)

C.T.S. system increases the efficiency of chip disposal and extends the tool life by cooling the cutting point.

Discharge pressure : 20/50/70 bar  
(2.0/5.0/7.0 Mpa)

Filtering accuracy : 40 μm

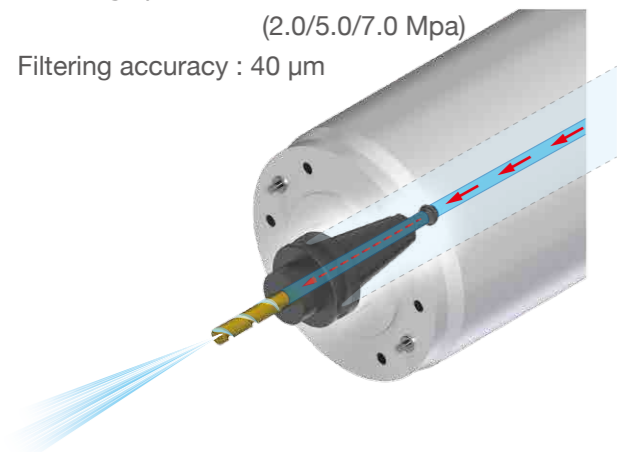

## Chip disposal

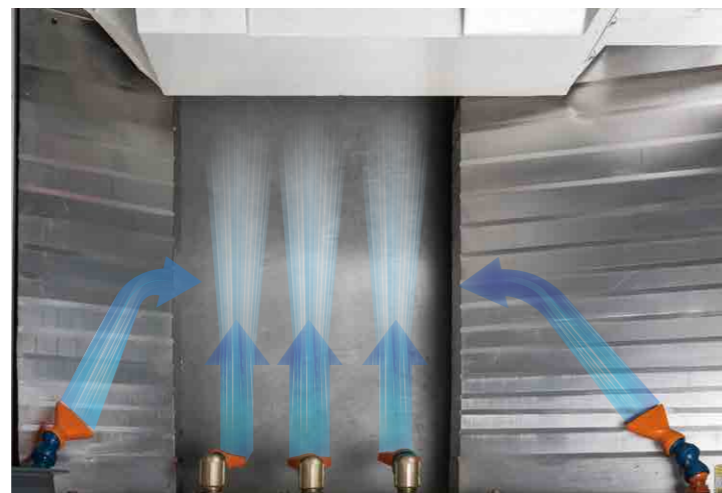

Widely slanted sheet metal with central chip disposal device allows chips efficient removing efficiently.

## Linear scale (Optional)

Linear scale is able to compensate the positioning error, repetition error, and pitch error of the ballscrew, which are caused by the temperature changing. The positioning accuracy achieves ±3μm with compensation of linear scales.



## Outer tool measurement device (opt.)

Equipped outside the machine to avoid interference between workpiece and tool.

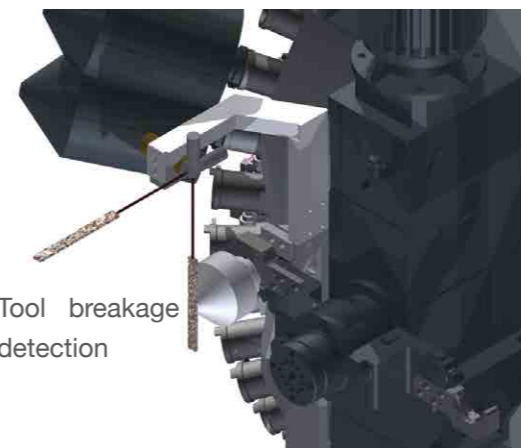

Tool breakage detection

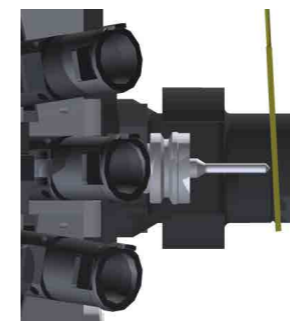

Tool length detection

## Workpiece measurement device (opt.)

Optionally equipped with workpiece measurement device that allows to process workpiece measurement immediately after the machining.

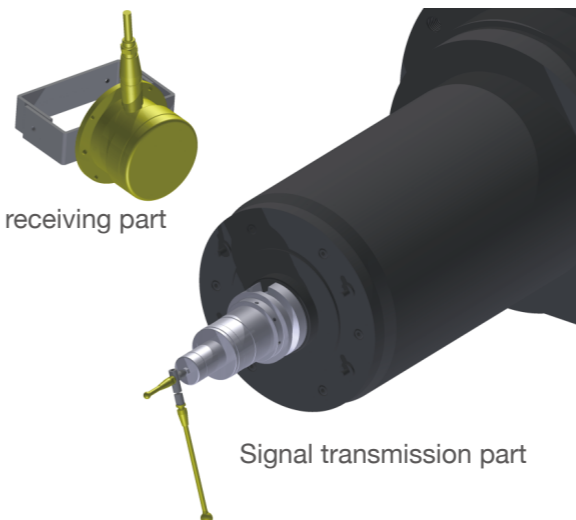

Signal receiving part

Signal transmission part

## Interior tool measuring device (optional)

It can measure tool length and tool diameter. In storage, it can be drawn back on the lateral side of the pallet to prevent interference from tool or workpiece.

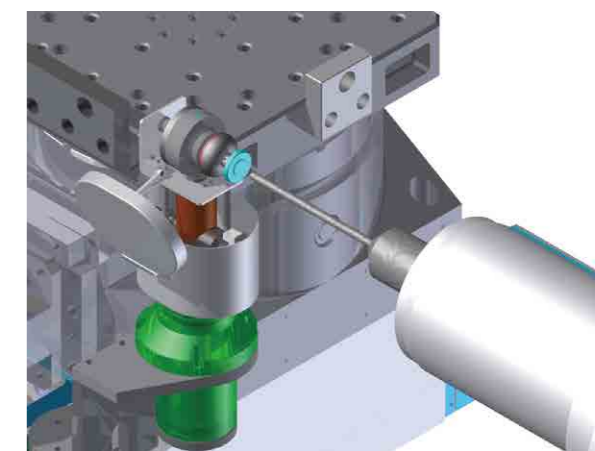

## Safety light curtain device (optional)

Safety light curtain device is available for avoiding accidental operation and ensuring operation safety.



# For green future

Because of rising energy costs and strict international environmental laws, the energy efficiency of production equipment is a key factor that can influence the production costs. By this trend, the machine tools are not only need to satisfy the requirements of high speed and high precision, but also need to pursue the goals of high efficiency and environmental protection. In recent years, It has worked hard on developing the products with the concept of being environmentally friendly. Besides improve machine efficiency, the energy saving accessories are used on machines.



LHL lubrication system

Variable-frequency hydraulic unit



Lubricant  
Save  
90%

Parts damage  
Decrease  
50%

Coolant life  
Improve  
200%



Power consumption  
Save  
55%

## Hydraulic and pneumatic supply for jig & fixture (Opt.)

1.Suspended arm type supply (With APC)(SH-4000P, SH-4500P, SH-5000P)  
Totally 6 ports are provided on each side and the maximum hydraulic pressure allowed is 250 bar.

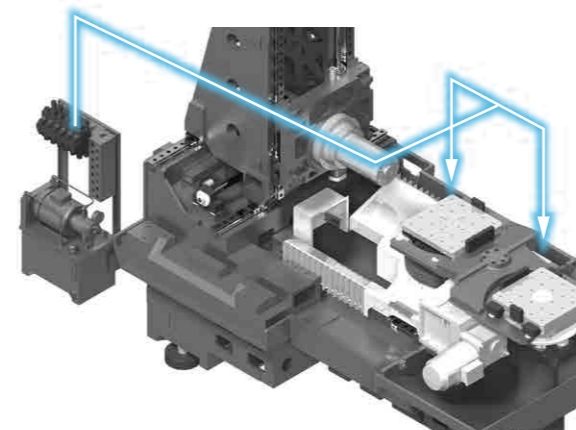

## Bottom oil passage supply (with APC system)

Inner the machine side

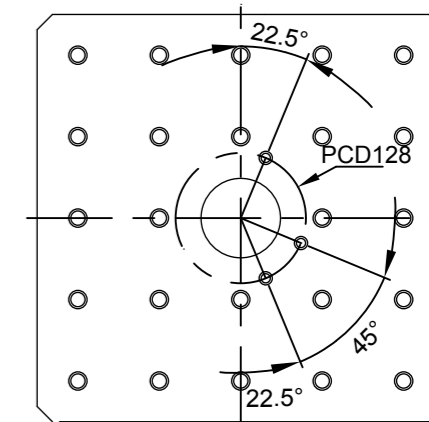

2.Hydraulic supply under pallet (With APC)(SH-4000P, SH-4500P, SH-5000P)  
In the situation of adopting APC system, through hydraulic couplers, it supplies oil and air pressures to the pallet on the turn station. For the couplers, there are 3 oil passages in the machine and 8 ones in the turn station.

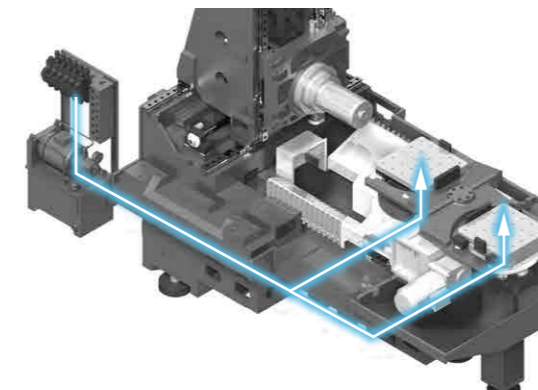

In the turn station side

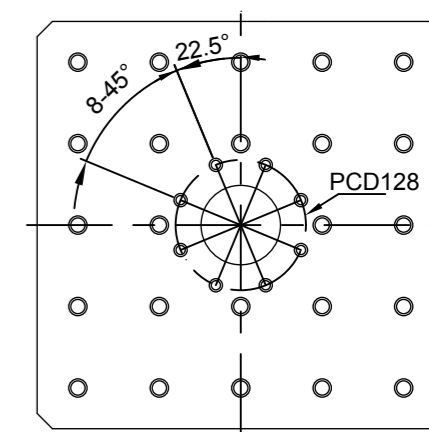

3.Hydraulic supply under pallet (w/o APC)(SH-4000, SH-4500, SH-5000)  
Adopts outer hydraulic couplers for supplying 8 oil passages in the pallet.

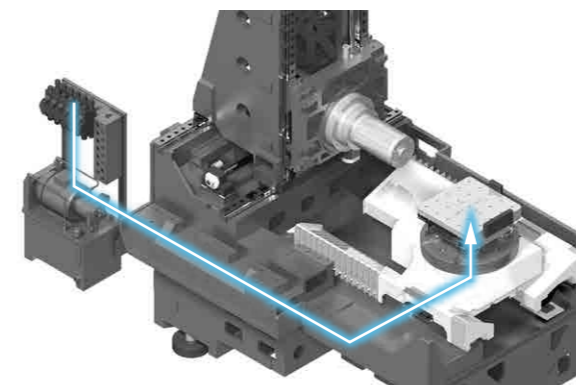

## Bottom oil passage supply (without APC system)

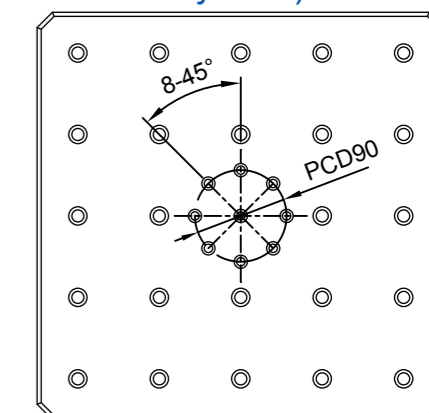

# TIMS Intelligent Manufacturing System(Opt.)

Considering productivity improvement, better machining precision, operating facilitation, as well as protection and maintenance assistance, TIMS includes four management functions: production management, intelligent monitoring, tool management, and workpiece management. These provide customers a comprehensive intelligence manufacturing system and a friendly human-machine interface.



## Production management

- Cutting Load Monitoring**  
The spindle and feeding axis motor loads are able to be monitored from the operation panel directly. The tool number is also shown during machining.
- APC Information**  
The operator is able to assign the program codes of A/B pallet in the operating interface directly and the system will call the corresponding programs of workpiece automatically.
- Machine Alarm Messages Record**  
Alarm messages will be recorded in detail during machine processing.
- Troubleshooting and Maintenance Support**  
Graphical display interface assists operators to understand detail alert and warning information.

## Intelligent monitoring

- Motor Load Monitoring**  
Monitoring and retrieving the motor load data during machining from the operation panel. In addition, according to the setting values, the system will show the alarm messages or shut down the machine.
- Machining Adaptive Control**  
Monitoring the spindle loads and the system enables automatic feeding adjustment to protect tools and ensure machining efficiency.
- Crush Protection**  
With the real-time detection of servo loads during feeding, the electrical brake is activated when a crash happens to minimize the damage.

## Tool management

- Tool Usage Time Tracking**  
Record the information of last machining date, time, and accumulated machining time in each tool.
- Tool Compensation**  
When the machining process needs tool length compensation, the operator is able to key in the compensation data for the tools.
- Tool Life Management**  
Display the tool life information and reminds the operator to check workpiece before tool life almost approaching its maximum.
- Tool Overload Protection**  
Display the information tool loads, spindle loads, machining time, abnormal data, and overload value of tools. When overload value reached, system will shut down the machine and show the alarm message.

## Workpiece management

- Workpiece positioning**  
The CCD camera is used to monitor the characteristics of workpiece, and then the system will calculate and compensate program coordinates for increasing machining precision.





# Working area • Spindle output and torque chart

# Pull stud/Tool shank type • Machine dimensions

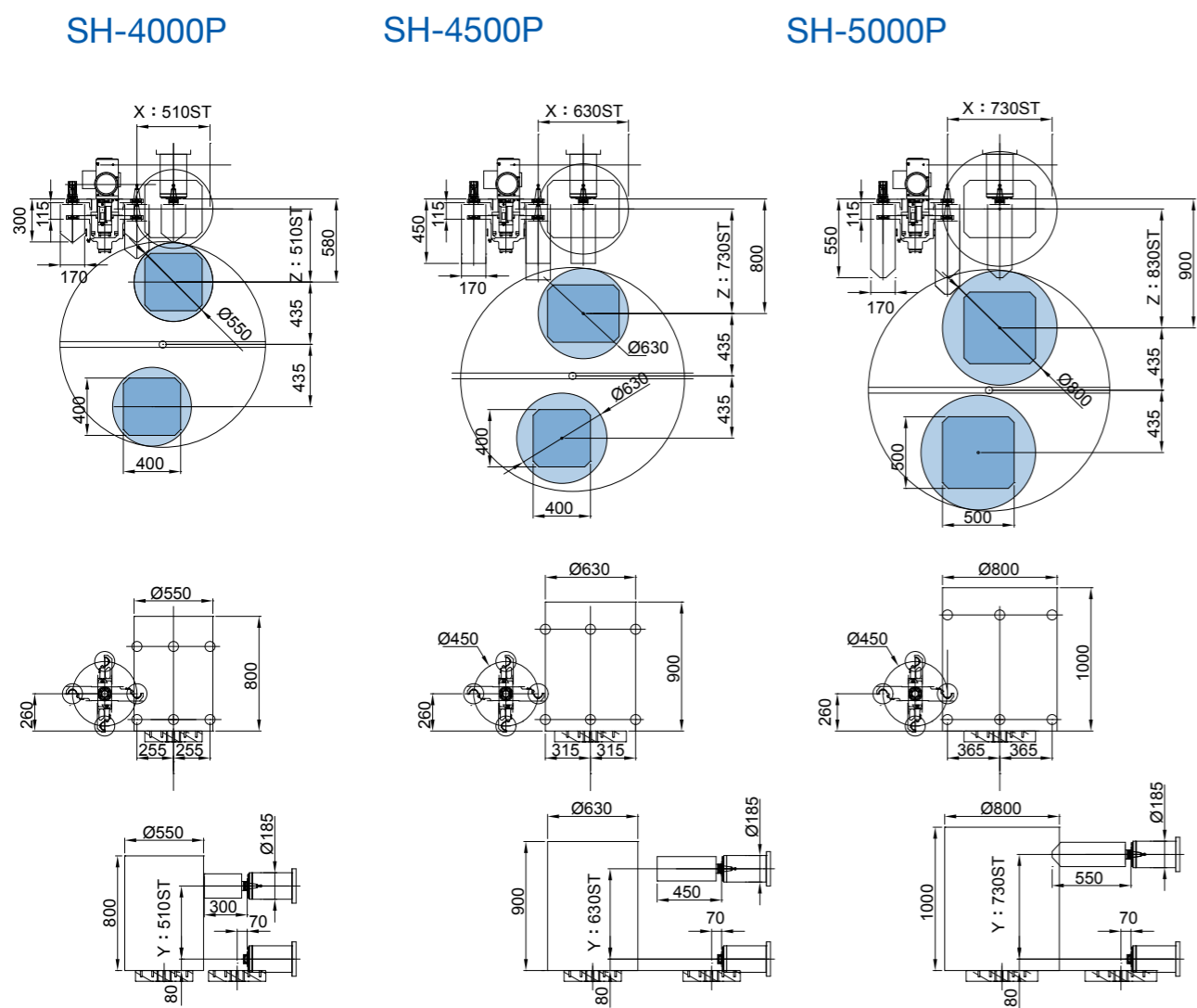

Unit : mm

Pull stud (C.T.S. A type)

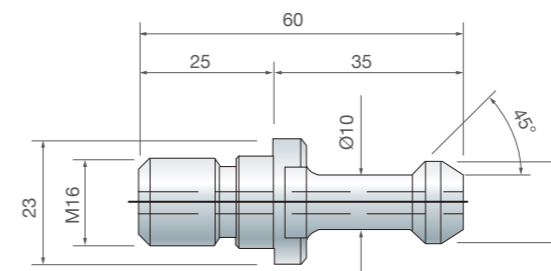

Tool shank type: MAS BT40

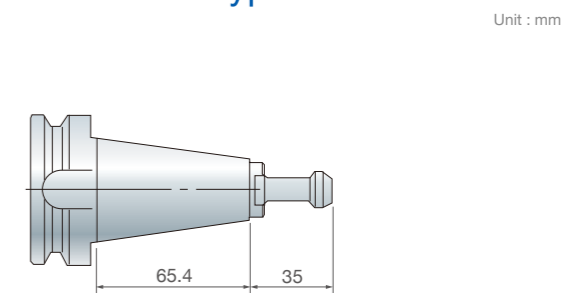

Unit : mm

SH series machine dimensions

項目	Unit	SH-4000P	SH-4500P	SH-5000P
W	mm	1,750	2,200	2,290
D	mm	5,060	5,700	5,840
H	mm	2,720	2,985	2,985

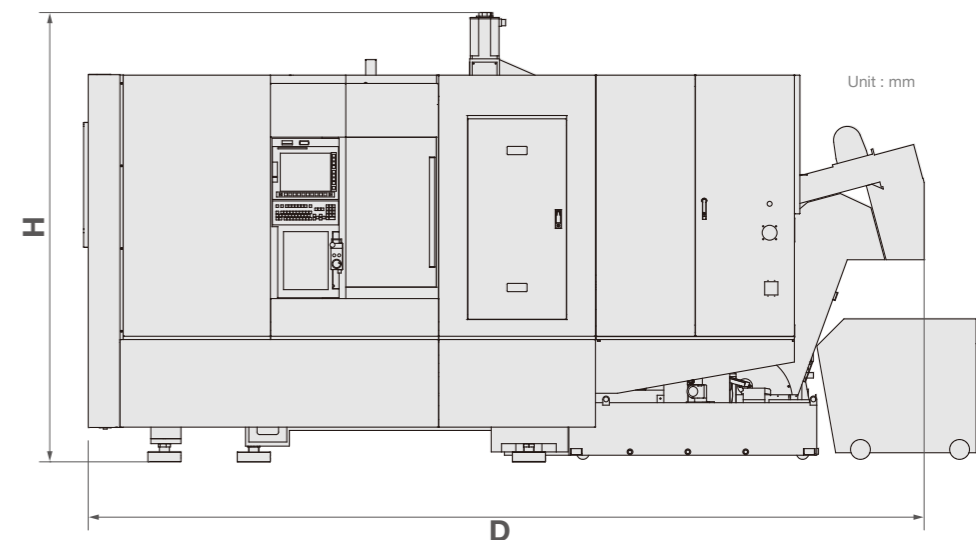
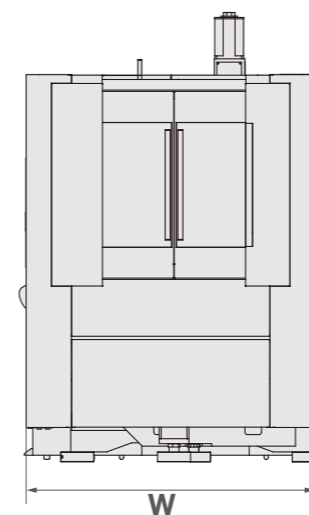

Unit : mm

## 15,000rpm built-in type spindle

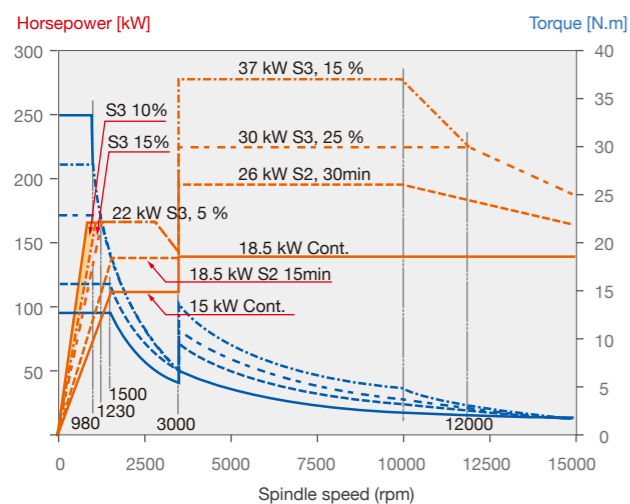

Pallet SH-4000(P), SH-4500(P)

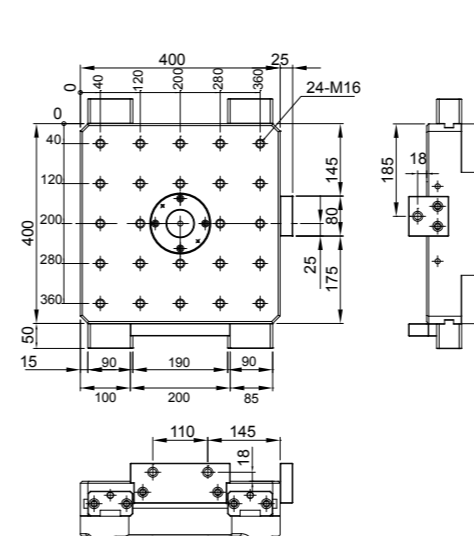

Pallet SH-5000(P), [SH-4500(P)(Opt.)]

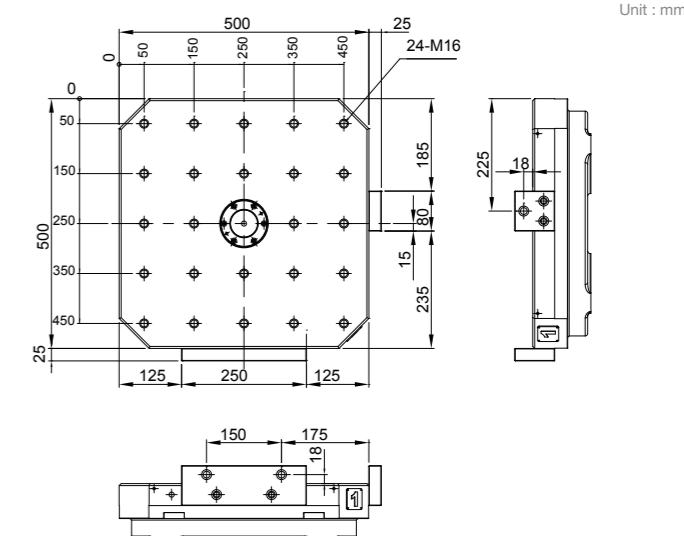

Unit : mm

## Standard/optional accessories

### SH Series

		Standard	Optional
Spindle	Built-in type 15,000 rpm	●	
B-axis	NC 0.001° index table (without rotary encoder)	●	
	NC 0.001° index table (with rotary encoder)		○
APC	Single pallet (SH-4000, SH-4500, SH-5000)	●	
	Dual pallet (SH-4000P, SH-4500P, SH-5000P)		○
Tool Shank	BBT-40	●	
	HSK-A63		○
	DIN-40		○
	CAT-40		○
Angle of BT-40 Pull stud	MAS407 BTI(45°)	●	
	MAS407 BTII(60°)		○
	MAS407 BTIII(90°)		○
Tool capacity	40 pc	●	
	60 pc		○
Coolant through spindle pump	20 bar	●	
	50 bar		○
	70 bar		○
Cooling system	Spindle coolant system	●	
	Air conditioner for electrical cabinet	●	
	Coolant temperature control system		○
	Hydraulic temperature control system		○
Chip conveyor	Central chip removing coolant system	●	
	Integrated type conveyor	●	
Lubrication system	LHL integrated lubrication system	●	
Positioning accuracy system	Three axes scal 5 μm resolution (Heidenhain)		○
Tool measuring system	Touch sensor(Installed in the interior of the machine for measuring tool length, tool breakage, and tool diameter)		○
	Outer tool sensor		○
	Workpiece measuring device		○
Others	Air gun	●	
	Coolant gun	●	
	Oil skimmer	●	
	Oil mist collector		○
	Machining air blow		○
Controller	FANUC 0i-MF 10.4"	●	
	FANUC 0i-MF 15"		○

## Specification

Item	Specification	Unit	SH-4000(P)	SH-4500(P)	SH-5000(P)
Pallet	Table size (L×W)	mm	400×400	400×400 (Opt. 500×500)	500×500
	Max. loading capacity	kg	400	450	500
	Table height from floor	mm	1,100	1,200	1,200
	Max. workpiece dimension (diameter x height)	mm	Ø550×800	Ø630×900	Ø800×1000
	Max. Indexing increment	deg	0.001°		
Spindle	Spindle taper		7/24 Taper No.40		
	Spindle speed	rpm	15,000		
Travel	X/Y/Z axis stroke	mm	510/510/510	630/630/730	730/730/830
	Spindle center to table	mm	80-590	80-710	80-810
	Spindle nose to table	mm	70-580	70-800	70-900
Feed	X/Y/Z axis rapid traverse	m/min	60/60/60		
	Cutting feedrate	mm/min	1-20,000		
ATC	Tool shank		BT-40(BBT-40)		
	Tool capacity	pc	40(Opt. 60)		
	Max. tool diameter	mm	Ø75		
	Max. tool diameter (w/o adjacent tool)	mm	Ø170		
	Max. tool length	mm	300	450	550
	Max. tool weight	kg	8		
Motor	Spindle motor	kW	37/26/18.5		
	X/Y/Z servo motor	kW	5.5/5.5/4.5		
	Coolant motor	kW	1.5×5		
Machine size	Width × Depth × Height	mm	1,750x4,210(5,060)x2,720	2,200x4,745(5,700)x2,985	2,290x4,885(5,840)x2,985
	Weight	kg	8,100(8,700)	11,100(11,800)	11,700(12,400)

©Specifications may be changed without prior notice